

Concrete strip roads for the farm



1. Introduction

Economical and durable all-weather roads, especially suitable for farms and rural areas, can be made with concrete strips laid as wheel-tracks.

Such roads have proved themselves in many countries. In Zimbabwe for example they gave excellent service over many years even on provincial-class routes carrying fast traffic.

These roads can be built without expensive or sophisticated equipment and by comparatively unskilled labour that has received a little instruction. The work can be done in short lengths as labour is available. Strip roads are a particularly useful means of making steep farm roads passable in all weathers.

2. Design

Dimensions

Except in long curves (where strips should be widened as required), strips 600 mm wide and 1 500 mm apart, centre to centre, are recommended, as shown in Figure 1.

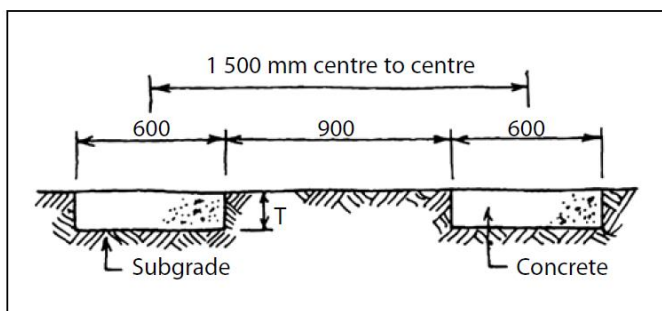

Figure 1: Cross section of road

Wheel tracks should be widened by 100 mm on the inside of curves and by 150 mm on sharp bends.

In all figures concrete thickness is indicated by "T".

The minimum thickness of concrete is as follows:

Maximum vehicle load 3,5 tons (ordinary farm traffic)	120 mm
Vehicle loads up to 5,5 tons	155 mm
Vehicle loads up to 7,5 tons	175 mm

Reinforcement is not necessary in the concrete.



Drainage

The strips should be built with a longitudinal slope of at least 1 in 100 (10 mm in 1 m) to ensure that stormwater will drain off the road. In addition, longitudinal edge drains should be considered where rainwater may tend to accumulate on the road, or where steep slopes may cause erosion of the road shoulders. Such drains should be constructed at least 1 m from the edge of the strips and an extra width of prepared roadway will thus be necessary. The roadway should be suitably sloped between the strips and the edge drains.

Subgrade

All top soil must be removed to a depth of at least 150 mm before the strips are constructed. The foundation below the concrete strips is called the subgrade and this must be compacted by using tampers or heavy rollers until it is firm.

Before excavating the strips, check the ground levels and correct any irregularities otherwise the strips will follow the undulations of the natural ground.

If during excavation of strips, soft, wet or unstable areas are detected, excavate such areas 300 mm deep and replace the excavated material with well compacted, granular fill.

Formwork

Rough-sawn SA Pine timber 38 mm thick may be used for longitudinal forms as follows:

Concrete thickness, mm	Width of timber, mm
120	114
155	152
175	170 (Ripped from 230)

Alternatively steel angles or channels can be used.

The forms are placed on edge and prevented from moving sideways by metal or wooden stakes driven into the ground no more than 1 m apart.

Forms for curved track can be made from strips of 6 mm hardboard or plywood that is suitably bent and held in position with stakes.

Transverse forms should be of planed timber and have strips of wood nailed to them to form the keyways (Figure 3).

Joints

Each strip must be divided into panels by transverse grooved or keyed joints (see Figures 2 and 3). The spacing of these joints is 1,5 m.

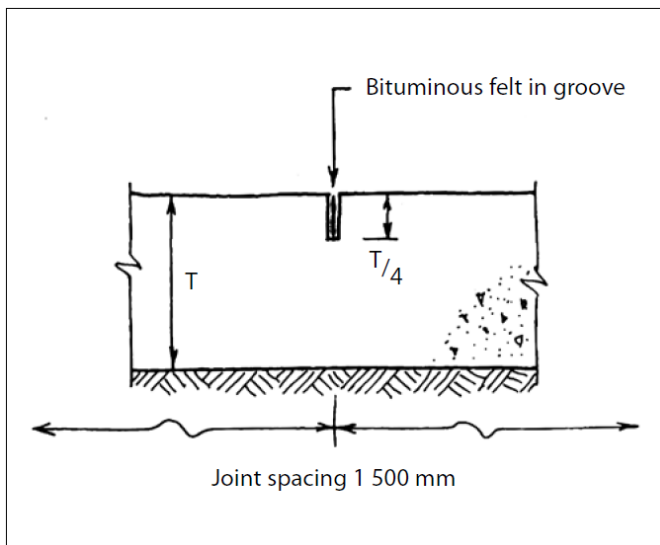

Figure 2: Longitudinal section through road showing grooved joint

Grooved joints are used where the strips are placed in a continuous operation in lengths considerably greater than 1,5 m. Keyed joints are used in the so-called alternate-panel method of construction, i.e. the first, third and fifth panels, etc., are placed on the first day, and the in-fill second, fourth and sixth panels on the second day, etc. Where continuous placing with grooved joints is interrupted for more than an hour, a keyed joint is required.

Concrete

All cement sold in South Africa must meet the requirements of SANS 50197 for Common cement or SANS 50413 for Masonry cement and the **National Regulator for Compulsory Standards (NRCS)** requirements as detailed in NRCS VC9085. Bags should

be clearly marked with the strength grade, notation indicating composition and a *Letter of Authority (LOA)* number issued by the NRCS. An LOA is issued for each cement type from each source. To verify valid LOA numbers contact the NRCS on 012 428 5199 or www.nrccs.org.za.

Note that Masonry cements complying with SANS 50413 are not permitted to be used in concrete.

Use the following materials:

- Cements complying with SANS 50197-1.
- Water – any water that is fit to drink.
- Sand – the size of particles should range from about 5 mm to dust.
- Stone – crushed stone or pebbles about 20 mm in size.

To make the concrete, mix 1 bag (50 kg) of cement with 65 ℓ of sand, 65 ℓ of stone and enough water to make the concrete workable and easy to compact by tamping. (The capacity of a builder's wheelbarrow is 65 ℓ). Do not add more water than is necessary as this will weaken the concrete.

For steep slopes the water content of the concrete mix should be reduced to prevent it from flowing downhill during compaction.

Mixing must be done by machine or by hand on a concrete floor or other smooth, clean, non-absorbent surface.

The volume of concrete produced by the above quantities will be approximately sufficient to place a strip 600 mm wide x:

- 120 mm thick x 1,5 m long, or
- 155 mm thick x 1,2 m long, or
- 175 mm thick x 1,0 m long,

all without anchors.

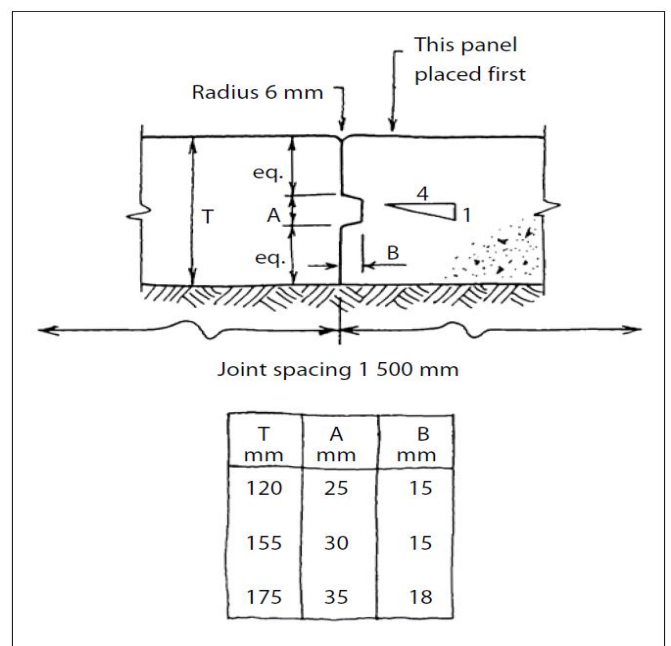

Figure 3: Longitudinal section through road showing keyed joint

Construction on steep slopes

Where strips are to be constructed on slopes steeper than 1 in 30 (33 mm in 1 m), the strips must incorporate panel anchors and anchor blocks in accordance with Table 1. Note that there should be a minimum of one anchor block at the bottom of each steep slope along with the required panel anchors, as per the provisions stated in Table 1. The panel anchors and anchor blocks prevent the completed strips from creeping downhill; details are shown in Figures 4 and 5.

Table 1: Provision of panel anchors and anchor blocks inroads on steep slopes

roadway slope	panel anchor	anchors blocks
flatter than 1 in 30	none	none
between 1 in 30 and 1 in 15	each third panel	at bottom end of the slope
between 1 in 15 and 1 in 10	each second panel	at bottom end of the slope
steeper than 1 in 10	each panel except where an anchor block is required	at bottom end of the slope and at 30 m intervals thereafter

3. Construction

Placing and compaction

The subgrade under the concrete must be damped ahead of concreting to prevent water being drawn out of the fresh concrete. However, any free surface water should be removed before concrete is placed.

Either the “continuous” or “alternate-panel” method of construction may be used. A screed board should be used to compact the concrete fully by tamping and to level it off. The screed board may be a piece of timber 38 mm x 100 mm x 800 mm long, which slides on the top of the formwork. It is first used with a chopping action to compact the concrete which should initially slightly over-fill the formwork; it is then used with a sawing motion to level off the concrete flush with the top edges of the forms.

For steep slopes where relatively stiff concrete will be necessary, consideration should be given to the use of a vibrating screed board for compacting the concrete. This consists essentially of a timber (or steel) member which can span across the forms and which has a vibrator attached to it at about mid-span. Only a small motor – possibly 100 to 200 W – is required. A poker vibrator would also be satisfactory. But if vibratory equipment is not available, it must be accepted that a fair amount of physical effort on the part of the laying gang will be needed to compact the concrete.

To make a grooved joint, a steel blade, about 3 mm wide and as long as the strip is wide, is forced down into the concrete to the depth of the groove required (see Figure 2). The blade is best worked into the concrete by attaching a vibrator to it. It is then withdrawn leaving a groove into which is dropped a strip of bituminous roofing felt (e.g. “Malthoid”) or heavy duty plastic cut to size. Surface finishing of the concrete can then be completed.

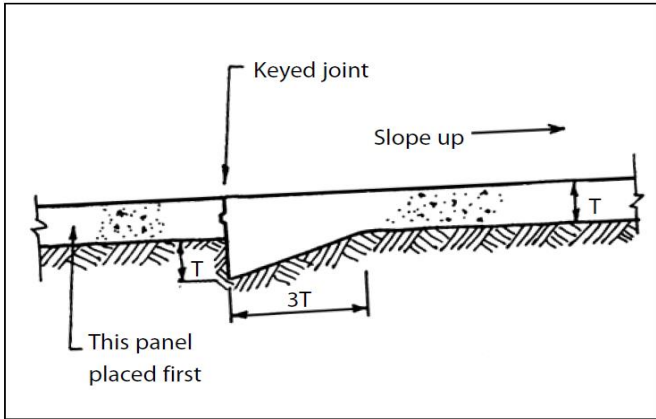

Figure 4: Panel anchor

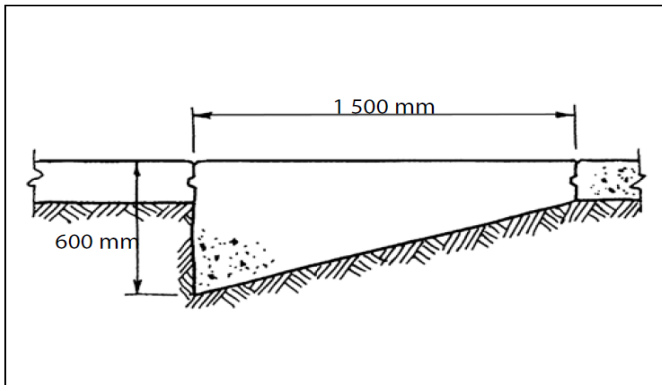

Figure 5: Anchor block

Panel anchors and anchor blocks are the same width as the strips. The recesses in the subgrade to form the panel anchors should be excavated shortly before the concrete is cast.

At the end of a strip road, the last panel should be thickened as in Figure 6, unless it is an anchor block, to prevent damage by traffic.

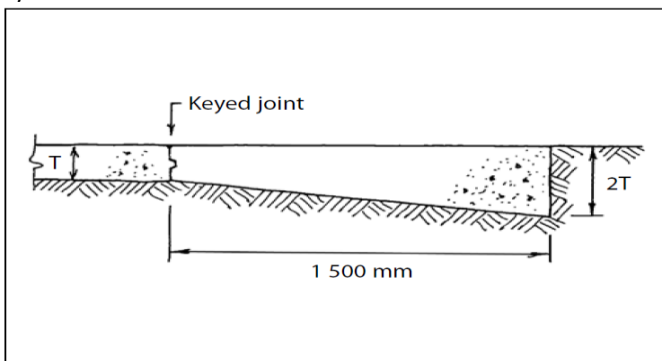

Figure 6: Panel at end of strip road

Surface finishing

Normally – and especially if the sand used for the concrete has an adequate proportion of fairly coarse particles – a satisfactory non-slip finish will be obtained simply by wood-floating the concrete as a final operation. However, on steep slopes, or if the sand is rather fine, or the mix is rather “fatty”, it may be better to finish the concrete, 1 to 2 hours after placing, by lightly brooming it transversely to the direction of travel so as to produce a multitude of fine grooves across it. Deep texturing is not required.

Protection and Curing

It is essential that concrete be prevented from drying out. If there is any delay between placing and finishing off the concrete, it needs to be protected especially in dry, windy weather. Covering with plastic sheeting is recommended until finishing occurs. For the concrete to develop strength, it should be kept damp for an adequate period after placing. Damp-curing should be continued for at least 10 days in warm weather and 14 days in cold weather. The curing procedure recommended is to cover the work, as soon as surface texturing is completed, with plastic sheeting that is kept in place with a thin layer of sand or soil over it and stones, planks, pipes or gum poles along the edges to stop the wind getting under the sheeting.

Opening to traffic

Full design loads should not be imposed on the concrete until it is at least 14 days but preferably 21 days old.

On the other hand, provided that they do not interfere with the damp-curing process, light vehicles such as cars and light trucks ($\frac{1}{2}$ ton rated capacity) can use the strips after 3 days of curing, and trucks of $1\frac{1}{2}$ ton capacity can use them after 7 days of curing.

These restrictions can substantially affect planning of work, as construction traffic – e.g. trucks carrying aggregates for concrete – commonly provide wheel loads that exceed those that the strips will be called upon to carry in normal service.

Cement & Concrete School of Technology, its directors, officers, employees, representatives and agents are not liable for any death, harm or injury caused to any person or any loss, destruction or damage caused to any person's property or possessions arising from goods supplied or services rendered by

Cement and Concrete School of Technology

Published by: Cement & Concrete School of Technology,
Midrand, 2024

© Cement and Concrete School of Technology